

# MDC-5400

## Mini Dome Day/Night, Vandal Proof Camera



INCORPORATED

Sophisticated Security and Surveillance Systems

### Features

- ✓ 540 TV Lines Color, 580 TV Lines B/W
- ✓ 1/3" Sony Super HAD CCD Image Sensor
- ✓ Excellent Sensitivity Minimum Illumination of 0.5 lux
- ✓ EI, Flickerless, BLC, AGC, AI
- ✓ Super BLC Selection
- ✓ Privacy Masking
- ✓ OSD (On Screen Display)
- ✓ Wall, Ceiling Mountable with 3-Axis Camera Mechanism
- ✓ Vandal Resistant, Rugged & High Impact
- ✓ Dual Power Operation DC12V / AC24V



### Description

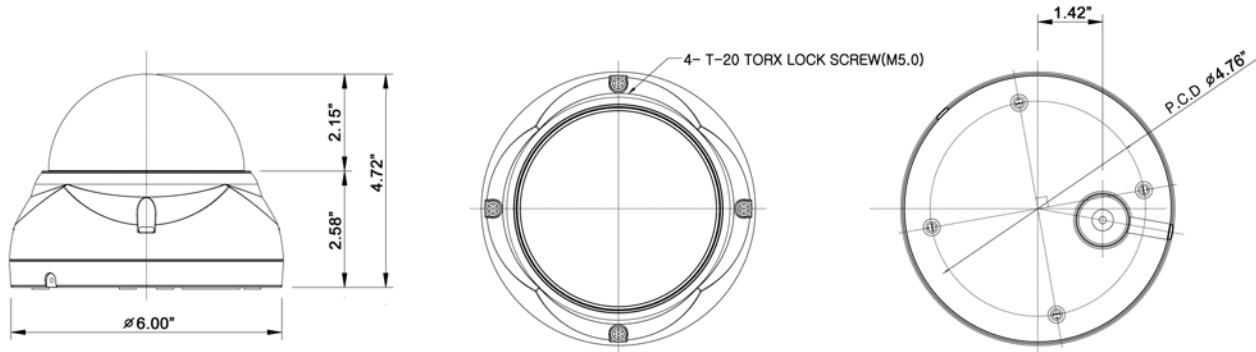

### Specifications

Video		General	
Signal Format	NTSC	Image Sensor	1/3" Sony Super-HAD CCD
Color Resolution	540 TV Lines	Total Pixels	811 (H) x 508 (V)
Monochrome Resolution	580 TV Lines	Scanning System	2:1 interlace
Min. Illumination	0.5 lux (Color), 0.04 lux (B/W) @ F1.2, 50 IRE	Scan Frequency	15.734 KHz (H), 59.94 Hz (V)
Video Output	1.0 Vp-p, 75 ohm composite	Sync System	Internal / Line lock
S/N Ratio	>50 dB (AGC off)	Operating Temperature	14°F to 104°F
Lens	f4~9 mm, F1.6~2.4, Varifocal DC, ICR	Operating Humidity	0-96% (non-condensing)
Function		Power	
Camera Control	A/D Key or Tact Switch	Power Source	DC 12V / AC 24V ±10%
Auto Exposure	Auto / Manual Shutter / Flickerless	Power Consumption	TBD
Shutter Speed	1/60 ~ 1/100,000 sec (9 Modes)	Mechanical	
Effect	Nega/Posi, Mirror, Gamma	Power Input	2-Pin Wire
White Balance	ATW / AWB / Indoor / Outdoor / Manual	Video Output	BNC Connector
AGC	On / Off (31dB Max)	Weight	TBD
BLC	On / Off (Selectable BLC Zone)		
Contour Selector	High / Normal		
Color Rolling	On / Off		
Day / Night	Auto / Color / BW		
Camera Title	A ~ Z / 0 ~ 9		
Display Title	On / Off		
Privacy Zone	On (4 point) / Off		
Preset	Default / Save & Exit / End		